

CJBDT/CBDT



Double inlet and direct motor extraction units and centrifugal fans for working inside fire danger zones 400°C/2h and 300°C/2h, with possibility of single-phase motor



Double inlet and direct motor extraction units and centrifugal fans for working inside fire danger zones 400°C/2h, with possibility of single-phase motor

Fan:

- Galvanised sheet steel casing
- Impeller with forward-facing blades made from galvanised sheet steel
- Outside connecting box.
- Anti-vibration dampers (CJBDT)
- Approval according to Standard EN 12101-3:2002/AC:2006, with certification No. 0370-CPR-0580



Motor:

- Class H motors, ongoing use S1 and emergency use S2, with ball bearings, IP55 protection, and one- or two- speed depending on the model.
- Single-phase 230V 50 Hz. and Three-phase 230/400V.50Hz. (up to 4HP) and 400/690V.-50Hz. (power over 4HP)
- Max. air temperature to transport: S1 Service -20°C + 60°C for ongoing use, S2 Service 300°C/2h, 400°C/2h

Finish:

- Anti-corrosive galvanised sheet steel.

On request:

- Fans with circular inlet
- Fans with vertical outlet



Outside connecting box and base stands



Single-phase motors, 400°C/2h

Order code



CJBDT: Double inlet and direct motor extraction units for working inside fire danger zones 400°C/2h and 300°C/2h, with possibility of single-phase motor

CBDT: Centrifugal double inlet and direct motor fans for working inside fire danger zones 400°C/2h and 300°C/2h, with possibility of single-phase motor

Turbine size

Number of motor pole
 2=2900 r/min. 50 Hz
 4=1400 r/min. 50 Hz
 6=900 r/min. 50 Hz
 8=750 r/min. 50 Hz
 12=500 r/min. 50 Hz

M= Single-phase
 T=Three-phase

Motor power (HP)

F-300 Officially approved, tested for 300°C/2h
 F-400 Officially approved 400°C/2h

CJBDT/CBDT

Technical characteristics

Model		Speed (r/min)	Maximum admissible current (A)			Power installed (kW)	Airflow maximum (m ³ /h)	Sound pressure level dB(A)		Approx. weight (Kg)	
			230V	400V	690V			CJBDT	CBDT	CJBDT	CBDT
CJBDT-9/9-4T	CBDT-9/9-4T	1420	2.90	1.70	0.55	3000	64	66	44	24	
CJBDT-9/9-4/8T	CBDT-9/9-4/8T	1440 / 710		1.76 / 0.76	0.55 / 0.15	3000 / 1750	64 / 51	66 / 53	45	25	
CJBDT-9/9-4M	CBDT-9/9-4M	1410	4.10		0.55	3000	64	66	44	23	
CJBDT-9/9-6T	CBDT-9/9-6T	920	1.50	0.90	0.25	2100	60	61	42	22	
CJBDT-9/9-6M	CBDT-9/9-6M	900	2.20		0.25	2100	60	61	42	21	
CJBDT-10/10-4T	CBDT-10/10-4T	1420	2.90	1.70	0.55	3450	67	68	49	26	
CJBDT-10/10-4/8T	CBDT-10/10-4/8T	1440 / 710		1.76 / 0.76	0.55 / 0.15	3450 / 1750	67 / 54	68 / 55	50	27	
CJBDT-10/10-4M	CBDT-10/10-4M	1410	4.10		0.55	3450	67	68	49	25	
CJBDT-10/10-6T	CBDT-10/10-6T	920	1.50	0.90	0.25	2250	63	64	47	24	
CJBDT-10/10-6M	CBDT-10/10-6M	900	2.20		0.25	2250	63	64	47	23	
CJBDT-12/12-6T-1	CBDT-12/12-6T-1	940	4.40	2.60	0.75	4800	64	65	69	37	
CJBDT-12/12-6/12T-1	CBDT-12/12-6/12T-1	935 / 430		2.50 / 1.03	0.75 / 0.15	4800 / 2600	64 / 52	65 / 53	72	41	
CJBDT-12/12-6M-1	CBDT-12/12-6M-1	920	5.80		0.75	4800	64	65	69	37	
CJBDT-12/12-6T-1.5	CBDT-12/12-6T-1.5	945	6.40	3.70	1.10	6200	65	67	71	39	
CJBDT-12/12-6/12T-1,5	CBDT-12/12-6/12T-1,5	940 / 450		3.30 / 1.20	1.10 / 0.18	6200 / 3250	65 / 53	67 / 55	75	44	
CJBDT-12/12-6M-1,5	CBDT-12/12-6M-1,5	920	8.40		1.10	6200	65	67	71	39	
CJBDT-15/15-6T	CBDT-15/15-6T	950	10.30	5.90	2.20	8250	67	68	110	68	
CJBDT-15/15-6/12T	CBDT-15/15-6/12T	940 / 470		5.60 / 2.20	2.20 / 0.37	8250 / 4600	67 / 54	68 / 55	116	74	
CJBDT-18/18-6T	CBDT-18/18-6T	970		11.00	6.35	4.00	11800	67	69	175	109
CJBDT-18/18-6/12T	CBDT-18/18-6/12T	970 / 480		11.30 / 4.20	4.00 / 0.65	11800 / 6600	67 / 54	69 / 56	183	117	
CJBDT-20/20-6T	CBDT-20/20-6T	970		14.00	5.50	14300	68	70	247	151	
CJBDT-20/20-6/12T	CBDT-20/20-6/12T	970 / 480		13.70 / 5.60	5.50 / 1.00	14300 / 9700	68 / 55	70 / 57	255	159	
CJBDT-22/22-6T	CBDT-22/22-6T	960		18.40	10.60	7.50	18050	69	71	309	190
CJBDT-22/22-6/12T	CBDT-22/22-6/12T	970 / 480		19.00 / 8.00	7.50 / 1.40	18050 / 11800	69 / 56	71 / 58	319	200	



Erp. BEP (best efficiency point) characteristics

<(°)	Angle of inclination of the blades, in degrees	SR	Specific ratio
PN	Motor's nominal power in kW	ηe[%]	Efficiency
MC	Measurement category	N	Efficiency grade
EC	Efficiency category	[kW]	Input power
S	Static	[m ³ /h]	Airflow
T	Total	[mmH ₂ O]	Static or total pressure (According to EC)
VSD	Variable-speed drive	[RPM]	Speed

	MC	EC	VSD	SR	ηe[%]	N	(kW)	(m ³ /h)	(mmH ₂ O)	(RPM)
CBDT-9/9-4T	A	S	NO	1.00	26.2%	34.0	0.588	1568	36.26	1453
CBDT-9/9-4/8T	A	S	NO	1.00	26.0%	33.7	0.596	1580	36.14	1465
CBDT-9/9-4M	A	S	NO	1.00	25.7%	33.4	0.598	1561	36.32	1447
CBDT-9/9-6T	A	S	NO	1.00	25.9%	37.2	0.165	1112	14.14	953
CBDT-9/9-6M	A	S	NO	1.00	25.4%	36.6	0.167	1098	14.23	942
CBDT-10/10-4T	A	S	NO	1.00	35.2%	42.1	0.808	2097	47.28	1437
CBDT-10/10-4/8T	A	S	NO	1.00	35.1%	42.0	0.814	2120	47.03	1453
CBDT-10/10-4M	A	S	NO	1.00	35.0%	41.9	0.811	2085	47.40	1429
CBDT-10/10-6T	A	S	NO	1.00	32.1%	42.5	0.225	1393	19.03	938
CBDT-10/10-6M	A	S	NO	1.00	31.7%	42.1	0.226	1370	19.22	923
CBDT-12/12-6T-1	A	S	NO	1.00	34.9%	42.1	0.728	3087	30.42	966
CBDT-12/12-6/12T-1	A	S	NO	1.00	34.8%	42.0	0.727	3078	30.45	963
CBDT-12/12-6M-1	A	S	NO	1.00	34.7%	41.9	0.723	3051	30.53	955
CBDT-12/12-6T-1.5	A	S	NO	1.00	35.4%	42.2	0.877	3723	30.11	973
CBDT-12/12-6/12T-1.5	A	S	NO	1.00	35.4%	42.1	0.877	3714	30.14	970
CBDT-12/12-6M-1.5	A	S	NO	1.00	35.3%	42.1	0.870	3676	30.28	960
CBDT-15/15-6T	A	S	NO	1.00	39.5%	43.9	2.101	5911	51.34	967
CBDT-15/15-6/12T	A	S	NO	1.00	38.7%	43.0	2.129	5870	51.37	960
CBDT-18/18-6T	A	S	NO	1.01	39.8%	42.1	4.421	9715	66.29	979
CBDT-18/18-6/12T	A	S	NO	1.01	39.6%	41.9	4.429	9673	66.39	974
CBDT-20/20-6T	A	S	NO	1.01	44.7%	46.6	5.208	9157	92.71	984
CBDT-20/20-6/12T	A	S	NO	1.01	43.8%	45.7	5.298	9126	92.73	980
CBDT-22/22-6T	A	S	NO	1.01	47.1%	47.8	7.827	13228	102.71	969
CBDT-22/22-6/12T	A	S	NO	1.01	46.1%	46.8	8.035	13333	102.54	977

CJBDT/CBDT

Acoustic features

The specified values are determined according to free field measurements of pressure and sound levels in dB(A) at an equivalent distance of twice the fan's span plus the impeller's diameter, with a minimum of 1.5 m.

Sound power Lw(A) spectrum in dB(A) via frequency band in Hz.

CBDT Model	63	125	250	500	1000	2000	4000	8000	CJBDT Model	63	125	250	500	1000	2000	4000	8000
9/9-4	46	56	64	68	73	72	69	61	9/9-4	51	66	70	69	68	65	65	55
9/9-6	43	54	59	66	67	67	62	56	9/9-6	47	62	66	65	64	61	61	51
9/9-8	34	45	51	57	60	59	55	48	9/9-8	44	51	57	57	54	50	53	48
10/10-4	48	58	66	70	75	74	71	63	10/10-4	54	69	73	72	71	68	68	58
10/10-6	46	57	62	69	70	70	65	59	10/10-6	50	65	69	68	67	64	64	54
10/10-8	36	47	53	59	62	61	57	50	10/10-8	47	54	60	60	57	53	56	51
12/12-6-1	47	58	63	70	71	71	66	60	12/12-6-1	51	66	70	69	68	65	65	55
12/12-6-1,5	49	60	65	72	73	73	68	62	12/12-6-1,5	52	67	71	70	69	66	66	56
12/12-12-1	34	45	51	57	60	59	55	48	12/12-12-1	45	52	58	58	55	51	54	49
12/12-12-1,5	46	53	59	59	56	52	55	50	12/12-12-1,5	46	53	59	59	56	52	55	50
15/15-6	63	72	74	76	71	70	64	55	15/15-6	63	72	74	76	71	70	64	55
15/15-12	51	54	63	60	58	60	60	48	15/15-12	51	54	63	60	58	60	60	48
18/18-6	64	74	76	78	73	72	66	57	18/18-6	64	74	76	78	73	72	66	57
18/18-12	53	56	65	62	60	62	62	50	18/18-12	53	56	65	62	60	62	62	50
20/20-6	67	77	79	80	76	74	69	60	20/20-6	67	77	79	80	76	74	69	60
20/20-12	55	59	68	65	63	65	64	53	20/20-12	55	59	68	65	63	65	64	53
22/22-6	69	79	81	83	78	77	71	62	22/22-6	69	79	81	83	78	77	71	62
22/22-12	58	61	70	67	65	67	67	55	22/22-12	58	61	70	67	65	67	67	55

Dimensions in mm

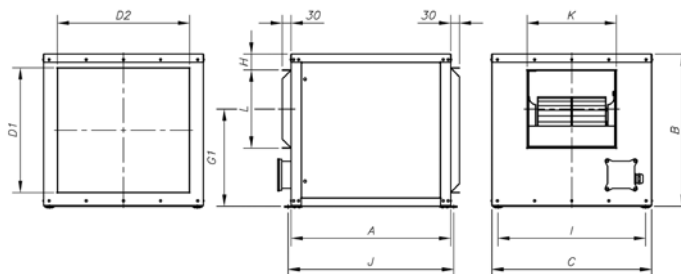

	A	B	C	D1	D2	G1	H	I	J	K	L
CJBDT-9/9	550	522	550	428	456	333,5	54,5	509	570	308	268
CJBDT-10/10	600	575	600	480	505	361,5	65,5	559	620	334	296
CJBDT-12/12	650	650	700	555	605	418	57,5	659	670	395	349
CJBDT-15/15	755	755	800	660	705	485	64	759	775	478	412
CJBDT-18/18	1000	900	1000	804	904	585	69,5	934	1041	550	491
CJBDT-20/20	1200	1175	1100	1070	1000	701	167,5	1040	1247	610	613
CJBDT-22/22	1280	1250	1250	1154	1154	739,5	158,8	1190	1327	664	704

Terminal box situation

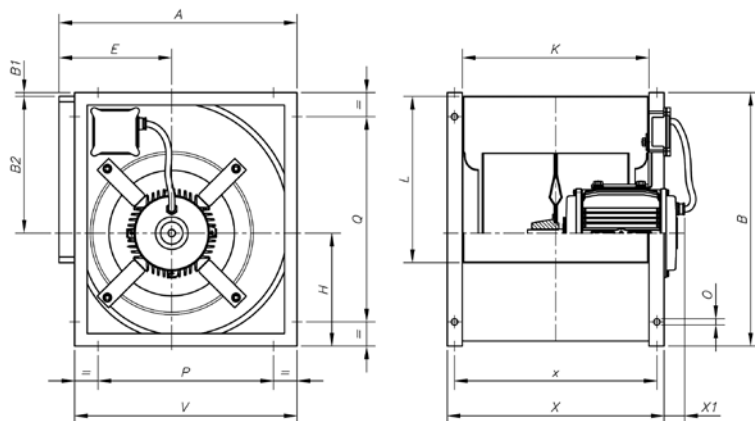

CBDT-9/9
10/10
12/12
15/15

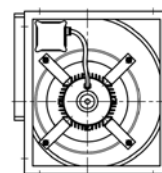

CBDT-18/18
20/20
22/22

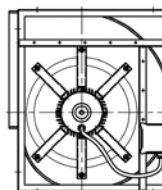

	A	B	B1	B2	E	H	K	L	P	Q	V	X	X1	x	O
CBDT-9/9	390	402	1,5	218	183	181	300	263	280	280	358	360	49	332	9x17
CBDT-10/10	430	448	2	246	202	204	326	292	326	326	398	388	33	360	9x17
CBDT-12/12	501	534	4	290	230	239,5	387	342	384	384	470	448	57	420	9x17
CBDT-15/15	584	630	-	348	265	280	473	405	460	460	550	535	58	507	9x17
CBDT-18/18	694	756	4	415	323	336	540	482	553	608	665	600	85	570	9x17
CBDT-20/20	839	935	6	523	372	406	602	604	595	735	795	682	58	642	12
CBDT-22/22	907	1019	6	571	399	442	655	695	663	819	863	735	105	695	12

CJBDT/CBDT

Characteristic curves

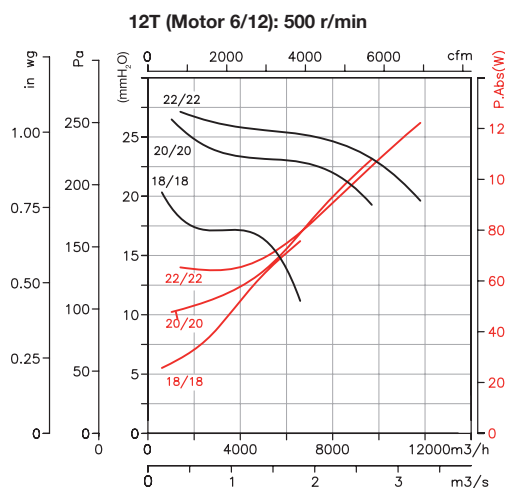
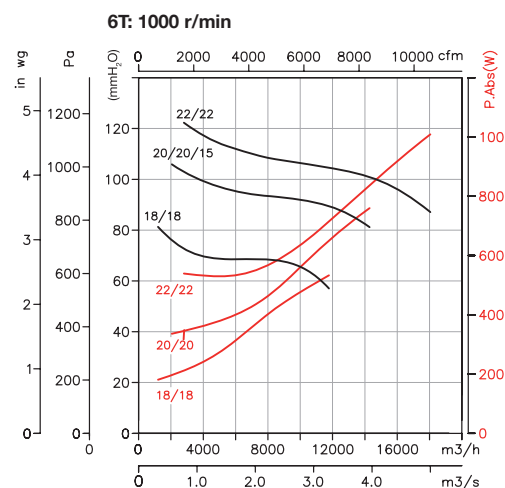
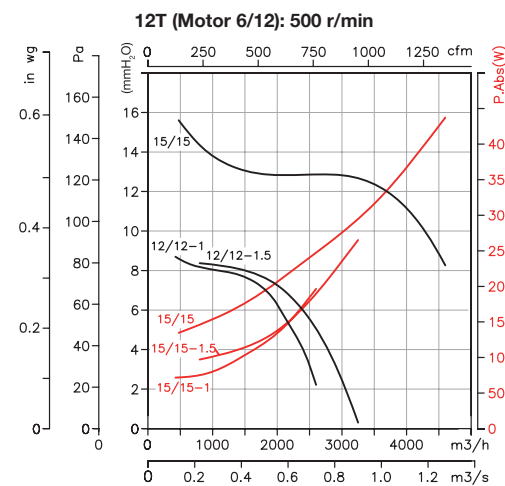
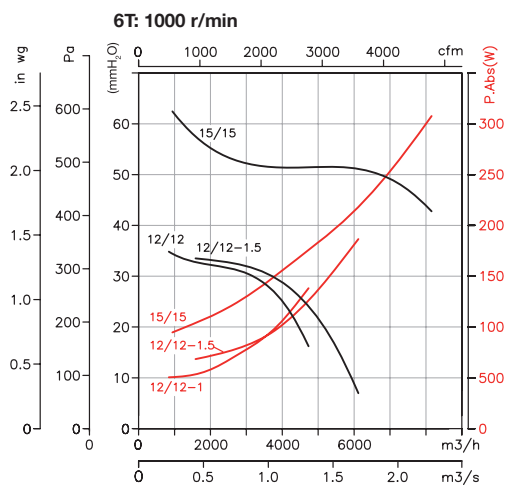
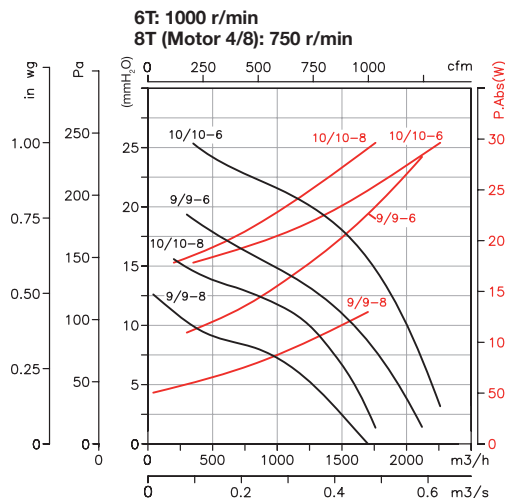
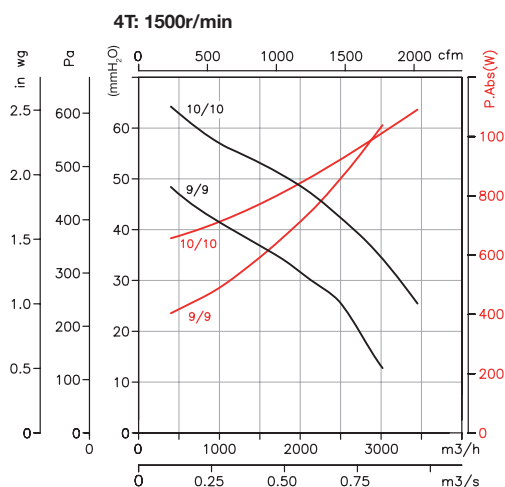

Accessories

See accessories section

